

vtech[®]

Parent's Guide

Helping Heroes Fire Station™



91-003871-000 

INTRODUCTION

Thank you for purchasing the **Helping Heroes Fire Station™!** Place firefighters Frankie and Fiona on the Talking Point location to hear fun sounds, music and phrases about their roles as firefighters. Press the three Action Buttons to get training, hear sound effects and see colorful lights. Press the Water Hose to pretend to spray water to put out the fire. You can transform the playset from the fire station to the fire truck for role-play fun!

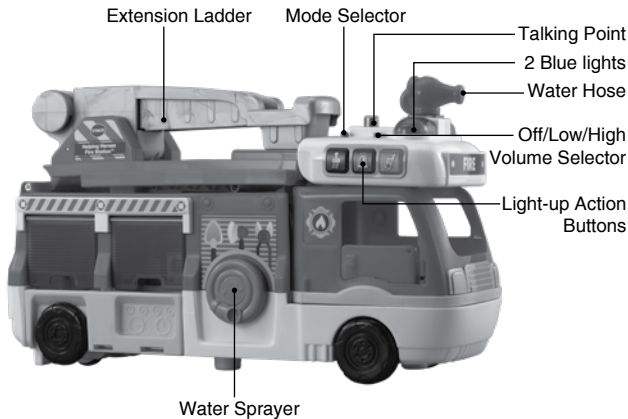

INCLUDED IN THIS PACKAGE

NOTE: This toy is not intended for teething.

This toy is not intended for playing in water.



• Fiona Firefighter



• Frankie Firefighter



• Rescue vehicle



• Helicopter



• Detachable ladder

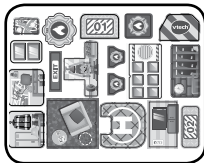

• Label sheet



• Helping Heroes Fire Station™

• Parent's guide

WARNING

All packing materials such as tape, plastic sheets, packaging locks, removable tags, cable ties and packaging screws are not part of this toy, and should be discarded for your child's safety.

NOTE

Please keep this parent's guide as it contains important information.

ATTENTION

Pour la sécurité de votre enfant, débarrassez-vous de tous les produits d'emballage tels que rubans adhésifs, feuilles de plastique, attaches, étiquettes et vis d'emballage. Ils ne font pas partie du jouet.

NOTE

Il est conseillé de conserver ce guide des parents car il comporte des informations importantes.

Unlock the Packaging Locks

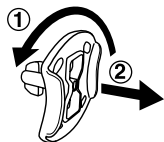

① Rotate the packaging locks counterclockwise 90 degrees.

② Pull out the packaging locks and discard.

Note: Please cut and discard the plastic tie between the door and the front of the truck before playing with the unit. This plastic tie is not part of the product and should be discarded for your child's safety.

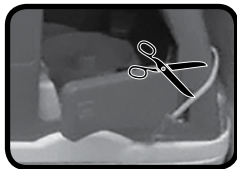

GETTING STARTED

Battery Removal and Installation

1. Make sure the unit is turned Off.
2. Find the battery cover located on the bottom right of the unit and use a screwdriver to loosen the screw and open the battery cover.
3. Remove old batteries by pulling up on one end of each battery.
4. Install 2 new AA (AM-3/LR6) batteries following the diagram inside the battery box.
5. Replace the battery cover and tighten the screw to secure.

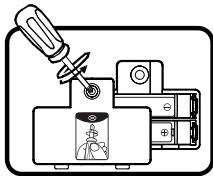

BATTERY NOTICE

- Use new alkaline batteries for maximum performance.
- Use only batteries of the same or equivalent type as recommended.
- Do not mix different types of batteries: alkaline, standard (carbon-zinc) or rechargeable, or new and used batteries.
- Do not use damaged batteries.
- Insert batteries with the correct polarity (+ and -).
- Do not short-circuit the battery terminals.
- Remove exhausted batteries from the toy.
- Remove batteries during long periods of non-use.
- Do not dispose of batteries in fire.
- Do not charge non-rechargeable batteries.
- Remove rechargeable batteries from the toy before charging (if removable).
- Rechargeable batteries are only to be charged under adult supervision.

MISE EN GARDE

- Utiliser des piles alcalines neuves pour des performances maximales.
- Seules des piles du type recommandé doivent être utilisées.
- Ne pas mélanger différents types de piles ou d'accumulateurs, ne pas mélanger des piles ou des accumulateurs neufs avec des usagés.
- Ne pas utiliser des piles ou des accumulateurs endommagés.
- Mettre en place les piles ou les accumulateurs en respectant les polarités + et - .
- Ne pas mettre les bornes d'une pile ou d'un accumulateur en court-circuit (en reliant directement le + et le -).
- Enlever les piles ou les accumulateurs usagés du jouet.
Retirer les piles ou les accumulateurs en cas de nonutilisation prolongée.
- Ne les jeter ni au feu ni dans la nature.
- Ne pas tenter de recharger des piles non rechargeables.
- Enlever les accumulateurs du jouet pour les recharger.
- Les accumulateurs ne doivent être chargés que sous la surveillance d'un adulte.

LABEL APPLICATION

Please securely stick the labels to the playset as indicated below:



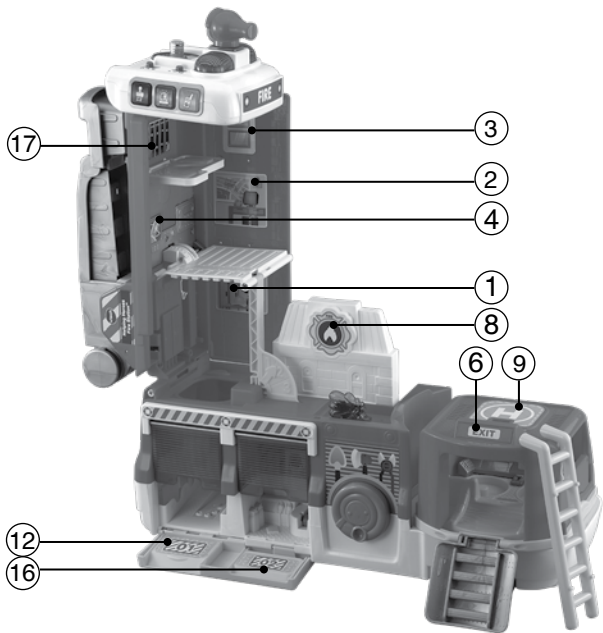

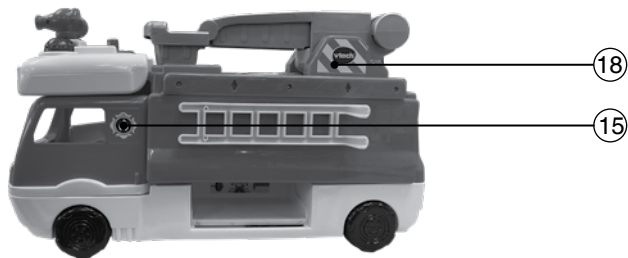
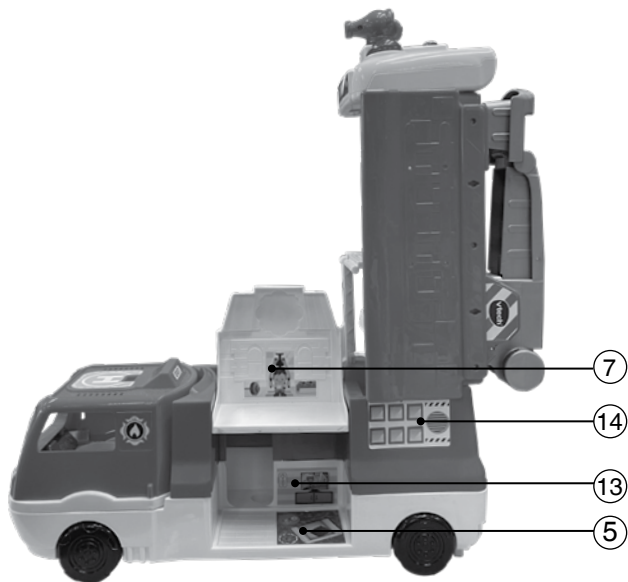



NOTE

This product is in Try-Me mode in the packaging. To activate Normal Play mode, please follow these steps.

1. Turn the unit **On**.
2. Place one **Firefighter** on the **Talking Point**.
3. When you hear two short sounds, normal game play has been activated.



PRODUCT FEATURES

1. Off/Low/High Volume Selector

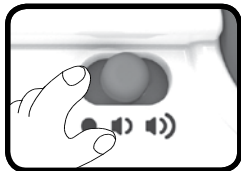
To turn the unit **On**, slide the **Off/Low/High Volume Selector** to either the Low volume  or High volume  position. To turn the fire station **Off**, slide the switch to the **Off**  position.



2. Mode Selector

Slide the **Mode Selector** to the left to enter Music & Sounds mode . Slide the **Mode Selector** to the middle to enter Explore & Train mode . Slide the **Mode Selector** to the right to enter Rescue Mission mode .

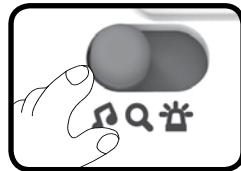

3. Action Buttons

Press the three **Action Buttons** to learn about colors, sounds and how to use rescue gear to carry out the rescue missions.



4. **Water Hose**

Press the **Water Hose** to help put out the fire.

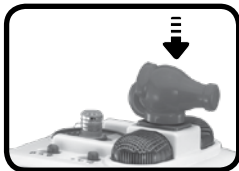

5. **Talking Point**

Place the characters onto the **Talking Point** location to hear fun responses.



6. **Transformation**

The playset can be transformed from a fire truck to a fire station and back again. Enjoy fun role-play in both modes.



- Lift up the top section of the truck.



- The cab of the truck twists counterclockwise.

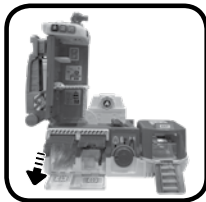

- Lift the doors and pull down the side of the truck.

7. Automatic Shut-Off

To preserve battery life, the **Helping Heroes Fire Station™** will automatically shut off after several minutes without input. The unit can be turned on again by sliding the **Off/Low/High Volume Selector** to the Low volume position or High volume position, or by sliding the **Mode Selector** to Music & Sounds mode, Explore & Train mode or Rescue Mission mode position.

ACTIVITIES

1. Mode 1: Music & Sounds Mode 🎵

Slide the **Mode Selector** to the left position to enter this mode. Press the three **Action Buttons** to hear sound effects and phrases. Place the characters onto the **Talking Point** location to hear melodies and songs.



2. Mode 2: Explore & Train Mode 🔍

Slide the **Mode Selector** to the middle position to enter this mode. Press three **Action Buttons** to learn about colors, facts about fire trucks and firefighting. Place the characters onto the **Talking Point** location to hear the characters talk, introduce themselves and more.



3. Mode 3: Rescue Mission Mode 🚒

Slide the **Mode Selector** to the right position to enter this mode. Press the **Action Buttons**, **Water Hose** or place the characters onto the **Talking Point** to play training and rescue games in fire truck and fire station.



MOTOR SKILL DEVELOPMENT

1. Move the **Firefighters'** workout room up to reveal more living space.

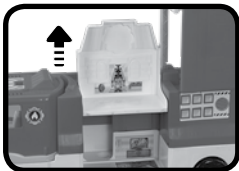

2. Drop a **Firefighter** through the opening and into the **Rescue Vehicle**.

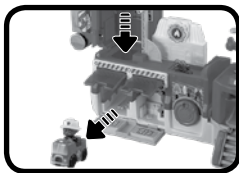

3. Put a **Firefighter** into the helicopter.
Help is on the way!

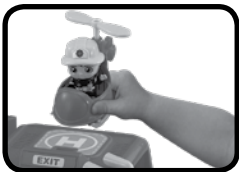

4. Need more water? Spin the revolving **Water Sprayer**.

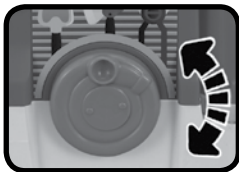

5. Put a **Firefighter** onto the **Extension Ladder** that can be raised and lowered.

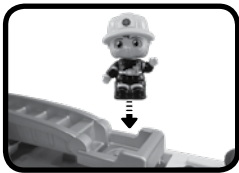

6. The **Detachable Ladder** stores on the fire truck.



7. Flip the water splash during pretend training exercises.



8. Place the **Firefighters** in the driver's and passenger's seats.



9. Flip the bed down and place a **Firefighter** there to take a nap.



10. Pretend to fuel up the vehicles with the included gas pump. If the gas pump becomes detached, it can be snapped easily back into place.



11. The fire truck door opens and closes. If the door becomes detached, it can be snapped easily back into place.

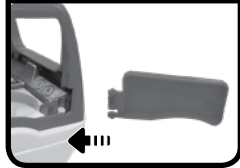

MELODIES

1. Hot Cross Buns
2. Alouette
3. Jack and Jill
4. Oats, Peas, Beans and Barley Grow
5. Old King Cole
6. Polly Put the Kettle on
7. London Bridge
8. Ring Around a Rosy

SONG LYRICS

Song 1

Firefighters, suit up!
We are firefighters and we're here to help
With our gear and our truck
Help is on the way!

Song 2

To rescue, to rescue, with sirens and lights
We'll help in any way, any day or any night!
To rescue, to rescue to help save the day
Back to the station, back home to stay.

Song 3

Up, up in a big tree, a kitty did climb
Now she's stuck up there, it's almost bedtime
She's too high to reach, oh what to do?
Call the fire department, and we'll come rescue.

Song 4

Oh dear, where can the fire be?
Oh dear, where can the fire be?
Oh dear, where can the fire be?
Don't worry, we'll put it out!

Song 5

Helicopter can really fly
Helicopter moves swift through the sky
All the heroes on land and in air
Work to help others because they care.

CARE & MAINTENANCE

1. Keep the product and its metal parts clean by wiping them with a slightly damp cloth.
2. Keep the unit out of direct sunlight and away from any direct heat sources.
3. Remove the batteries if the unit will not be in use for an extended period of time.
4. Do not drop the unit on a hard surfaces and do not expose the unit to moisture or water.

TROUBLESHOOTING

If for some reason the unit stops working or malfunctions while a character is on the **Talking Point**, please remove the character and place it back onto the **Talking Point**. If the unit still does not function, or if for some reason the unit stops working or malfunctions on its own, please follow these steps:

1. Turn the unit **Off**.
2. Interrupt the power supply by removing the batteries.
3. Let the unit stand for a few minutes, then replace the batteries.
4. Turn the unit **On**. The unit should now be ready to use again.
5. If the unit still does not work, install a new set of batteries.

IMPORTANT NOTE

If the problem persists, please call our **Consumer Services Department** at **1-800-521-2010** in the U.S. or **1-877-352-8697** in Canada, or visit our website at **vtechkids.com** and fill out our **Contact Us** form located under the **Customer Support** link. Creating and developing **VTech®** products is accompanied by a responsibility that we take very seriously. We make every effort to ensure the accuracy of the information, which forms the value of our products. However, errors sometimes can occur. It is important for you to know that we stand behind our products and encourage you to contact us with any problems and/or suggestions that you might have. A service representative will be happy to help you.

NOTE

This equipment has been tested and found to comply with the limits for a Class B digital device, pursuant to Part 15 of the FCC Rules. These limits are designed to provide reasonable protection against harmful interference in a residential installation. This equipment generates, uses and can radiate radio frequency energy and, if not installed and used in accordance with the instructions, may cause harmful interference to radio communications. However, there is no guarantee that interference will not occur in a particular installation. If this equipment does cause harmful interference to radio or television reception, which can be determined by turning the equipment off and on, the user is encouraged to try to correct the interference by one or more of the following measures:

- Reorient or relocate the receiving antenna.
- Increase the separation between the equipment and receiver.
- Connect the equipment into an outlet on a circuit different from that to which the receiver is connected.
- Consult the dealer or an experienced radio/TV technician for help.

CAUTION

Changes or modifications not expressly approved by the party responsible for compliance could void the user's authority to operate the equipment.

**Supplier's Declaration of Conformity
47 CFR § 2.1077 Compliance Information**

Trade Name: VTech®
Model: 5298
Product Name: Helping Heroes Fire Station™
Responsible Party: VTech Electronics North America, LLC
Address: 1156 W. Shure Drive, Suite 200
Arlington Heights, IL 60004
Website: vtechkids.com

THIS DEVICE COMPLIES WITH PART 15 OF THE FCC
RULES. OPERATION IS SUBJECT TO THE FOLLOWING TWO
CONDITIONS:

(1) THIS DEVICE MAY NOT CAUSE HARMFUL INTERFERENCE,
AND (2) THIS DEVICE MUST ACCEPT ANY INTERFERENCE
RECEIVED, INCLUDING INTERFERENCE THAT MAY CAUSE
UNDESIRED OPERATION.

CAN ICES-3 (B)/NMB-3(B)

**CLASS 1
LED PRODUCT**

**Visit our website for more
information about our products,
downloads, resources and more.**

vtechkids.com

Read our complete warranty policy online at
vtechkids.com/warranty



TM & © 2020 VTech Holdings Limited.

All rights reserved.

Printed in China.

91-003871-000 (US) (CN)